







Curvas de cargas - Load diagrams - Lastkurven - Courbes de charges - Curve di carico - График грузоподъёмности



50 m

Max. load	10	15	20	25	30	35	40	45	50	m
38.4m	4000	4000	4000	4000	4000	4000	3870	3380	3000	Kg
41.1m	4000	4000	4000	4000	4000	4000	4000	3740	3300	Kg Superlift 
26.8m	6000	6000	6000	6000	5250	4440	3910	3400	3000	Kg
28.7m	6000	6000	6000	6000	5800	4880	4280	3740	3300	Kg Superlift 
19.0m	8000	8000	7930	6540	5260	4450	3910	3400	3000	Kg
21.0m	8000	8000	8000	7140	5800	4880	4290	3740	3300	Kg Superlift 



45 m

Max. load	10	15	20	25	30	35	40	45	m
41.0m	4000	4000	4000	4000	4000	4000	4000	3600	Kg
45.0m	4000	4000	4000	4000	4000	4000	4000	4000	Kg Superlift 
27.4m	6000	6000	6000	6000	6000	5330	4570	4000	Kg
30.5m	6000	6000	6000	6000	5670	4800	4120	3600	Kg Superlift 
20.7m	8000	8000	8000	6930	5690	4800	4120	3600	Kg
20.7m	8000	8000	8000	7650	6290	5320	4570	4000	Kg Superlift 



40 m

Max. load	10	15	20	25	30	35	40	m
40.0m	4000	4000	4000	4000	4000	4000	4000	Kg
40.0m	4000	4000	4000	4000	4000	4000	4000	Kg Superlift 
30.7m	6000	6000	6000	6000	6000	5270	4500	Kg
32.9m	6000	6000	6000	6000	6000	5780	4950	Kg Superlift 
22.9m	8000	8000	8000	7520	6290	5270	4500	Kg
25.8m	8000	8000	8000	8000	6900	5790	4950	Kg Superlift 



35 m

Max. load	10	15	20	25	30	35	m
35.0m	4000	4000	4000	4000	4000	4000	Kg
35.0m	4000	4000	4000	4000	4000	4000	Kg Superlift 
33.6m	6000	6000	6000	6000	6000	5700	Kg
35.0m	6000	6000	6000	6000	6000	6000	Kg Superlift 
25.0m	8000	8000	8000	8000	6850	5700	Kg
25.8m	8000	8000	8000	8000	7560	6300	Kg Superlift 



30 m

Max. load	10	15	20	25	30	m
30.0m	4000	4000	4000	4000	4000	Kg
30.0m	4000	4000	4000	4000	4000	Kg Superlift 
30.0m	6000	6000	6000	6000	6000	Kg
30.0m	6000	6000	6000	6000	6000	Kg Superlift 
26.2m	8000	8000	8000	8000	7000	Kg
28.8m	8000	8000	8000	8000	7700	Kg Superlift 





25 m

Max. load	10	15	20	25	m
25.0m	4000	4000	4000	4000	Kg
25.0m	4000	4000	4000	4000	Kg Superlift 
25.0m	6000	6000	6000	6000	Kg
25.0m	6000	6000	6000	6000	Kg Superlift 
25.0m	8000	8000	8000	8000	Kg
25.0m	8000	8000	8000	8000	Kg Superlift 



20 m







Max. load	10	15	20	m
25.0m	4000	4000	4000	Kg
25.0m	4000	4000	4000	Kg Superlift 
25.0m	6000	6000	6000	Kg
25.0m	6000	6000	6000	Kg Superlift 
25.0m	8000	8000	8000	Kg
25.0m	8000	8000	8000	Kg Superlift 



Mecanismos - Mechanisms - Antriebe - Mécanismes - Meccanismi

50 Hp (37Kw) INV											
	LEBUS 715m  H. 330m Ø12,5					LEBUS 715m  H. 220m Ø12,5					
		m/min	0--42*	0--57	0--68	0--96	0--124	0--31*	0--43	0--51	0--72
	Kg	4000	3000	2400	1600	1000	6000	4500	3600	2400	1500
	Kw	37	37	37	37	37	37	37	37	37	37





* Max. hoisting speed with Superlift mode activated

				
LEBUS 715m  H. 165m Ø12,5				
0--21*	0--28	0--34	0--48	0--62
8000	6000	4800	3200	2000
37	37	37	37	37

			
		2 min. de 1° a 85° 2 minutes from 1° to 85°	
	Kw	22	
	r.p.m	0--0,8	
	Nm	2 x 85	
	m/min	12--24	
	Kw	4 x 3	

		400 V 50 Hz 60 Hz	100 m 4 x 35 mm ²
2000/14/CEE 2005/88/CEE	2006/95/CEE		

	37 Kw	74 Kw	145 kVA
---	-------	-------	---------

- * Opcional / Optional / Opzionale
-  Elevación / Hoisting / Heben / Levage / Sollevamento
-  Elevación de pluma / Luffing / Ausleger-Einziehen / Relevage / Brandeggio
-  Orientación / Slewing / Schwenken / Orientation / Rotazione
-  Traslacion / Travelling / Schienenfahren / Translation / Traslazione
-  Cable / Rope / Seil / Câble / Fune

FEM 1005-C25 / EN 14439- Mástil / Reacciones- Masts / Reactions- Maste / Eckdrücke-
Mat / Réactions- Torre / Réazioni / Реакции - Комплектация башни

S21

- O = S21 8/8
- P = S21 16/8
- P = S21 16/16
- T = S2322 16/15 M45L
- U = S2326 16/16 M52L
- X = C2322/21
- Z = S2330 16/24 M52L
- ZR = S2330R 24/24 M52L

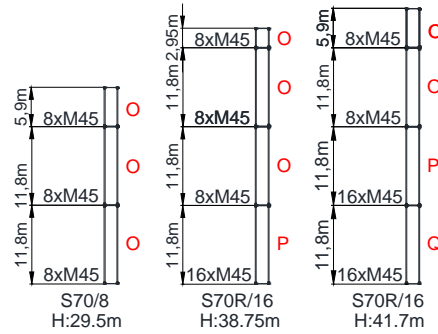

50 m



C25	TH (m)	29.5	38.75	41.7
	M (T·m)	402.3	531.6	589.5
	T (t)	12.8	14.3	15.3
	P (t)	60.9	65.9	66.3
	R ₁ (t)	126.8	176.2	197.1
	R ₂ (t)	-155.8	-209.1	-230.3

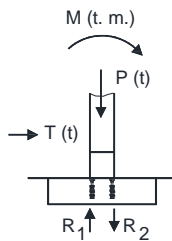

S23

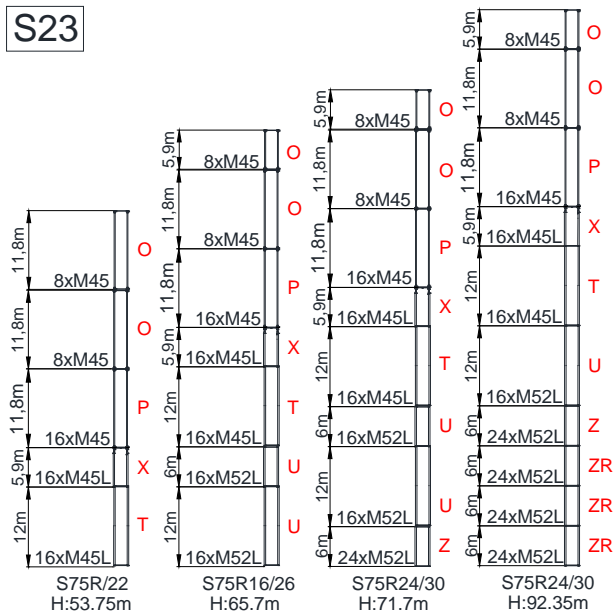

50 m



C25	TH (m)	53.75	65.7	71.7	83.7
	M (T·m)	831.0	1142.1	1325.0	1744.7
	T (t)	19.5	24.7	27.1	32.1
	P (t)	79.2	96.3	103.0	116.5
	R ₁ (t)	266.8	369.8	431.2	572.7
	R ₂ (t)	-306.4	-418.0	-482.73	-630.9

FEM 1005-C25-D25 / EN 14439- Bloque lastre de base- Base ballast block- Grundballastblöcke - Bloc de lest de base- Blocco di zavorra alla base - Балласты опорной рамы

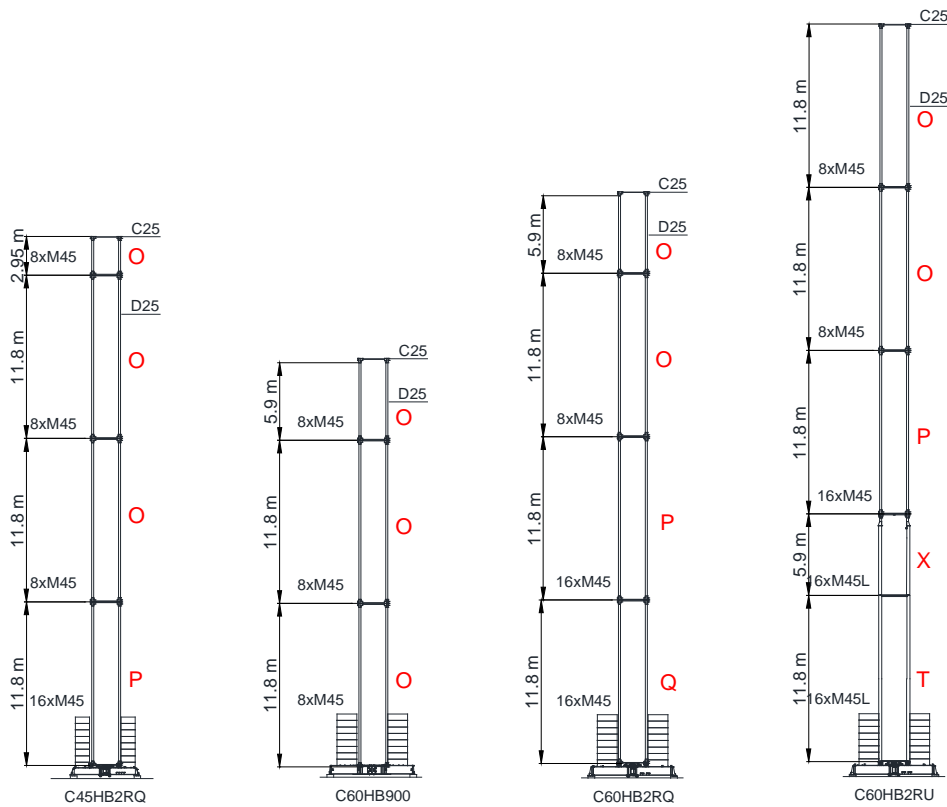

C45HB2RQ	C25	JIB (m)	50 m	45 m	40 m	35 m	30 m	25 m	20 m
		TH (m)	39.45m	42.4 m	45.35 m	48.3 m	48.3 m	51.25 m	51.25 m
		T (t)	15.5	16.6	16.7	16.9	16.9	17.1	17.1
		R1 (t)	229.6	255.7	266.6	282.2	282.2	281.8	281.8
		Z (t)	160 t	180 t	180 t	200 t	200 t	200 t	200 t

C45HB2RQ	D25	JIB (m)	50 m	45 m	40 m	35 m	30 m	25 m	20 m
		TH (m)	33.55 m	33.55 m	36.5 m	33.85 m	36.8 m	39.75 m	39.75 m
		T (t)	16.6	16.6	16.9	17.2	17.2	17.7	17.7
		R1 (t)	201.6	201.6	216.8	227.2	227.2	232.0	232.0
		Z (t)	120 t	120 t	140 t	160 t	160 t	160 t	160 t

C60HB900	C25	JIB (m)	50 m	45 m	40 m	35 m	30 m	25 m	20 m
		TH (m)	30.9 m	30.9 m	33.85 m	36.8 m	39.75 m	39.75 m	39.75 m
		T (t)	14.2	14.2	14.3	14.5	15.2	15.2	15.2
		R1 (t)	127.8	127.8	138.1	143.7	154.2	154.2	154.2
		Z (t)	56 t	56 t	76 t	76 t	76 t	76 t	76 t

C60HB900	D25	JIB (m)	50 m	45 m	40 m	35 m	30 m	25 m	20 m
		TH (m)	27.95 m	27.95 m	30.9 m	33.85 m	36.8 m	39.75 m	39.75 m
		T (t)	15.4	15.4	16.0	16.3	16.6	17.4	17.4
		R1 (t)	121.4	121.4	131.8	142.4	147.8	163.3	163.3
		Z (t)	56 t	56 t	56 t	76 t	76 t	96 t	96 t

C60HB2RQ	C25	JIB (m)	50 m	45 m	40 m	35 m	30 m	25 m	20 m
		TH (m)	42.7 m	45.75 m	48.6 m	48.6 m	51.65 m	54.6 m	54.6 m
		T (t)	18.8	19.4	19.5	19.5	19.9	20.0	20.0
		R1 (t)	198.2	219.4	225.3	225.3	230.1	235.4	235.4
		Z (t)	136 t	136 t	136 t	136 t	156 t	156 t	156 t

C60HB2RQ	D25	JIB (m)	50 m	45 m	40 m	35 m	30 m	25 m	20 m
		TH (m)	39.75 m	39.75 m	42.7 m	45.65 m	45.65 m	48.6 m	48.6 m
		T (t)	19.1	19.1	15.1	15.3	15.3	14.9	14.9
		R1 (t)	198.0	198.0	177.9	188.5	188.5	182.7	182.7
		Z (t)	116 t	116 t	116 t	116 t	116 t	116 t	116 t

C60HB2RU	C25	JIB (m)	50 m	45 m	40 m	35 m	30 m	25 m	20 m
		TH (m)	54.9 m	54.9 m	57.85 m	60.8 m	60.8 m	63.7 m	63.7 m
		T (t)	23.1	23.1	23.2	24.1	24.1	23.8	23.8
		R1 (t)	293.0	293.0	303.4	319.0	319.0	313.4	313.4
		Z (t)	196 t	196 t	216 t	216 t	216 t	216 t	216 t

C60HB2RU	D25	JIB (m)	50 m	45 m	40 m	35 m	30 m	25 m	20 m
		TH (m)	48.9 m	48.9 m	51.85 m	54.8 m	54.8 m	57.75 m	57.75 m
		T (t)	22.9	22.9	24.0	24.4	24.4	24.3	24.3
		R1 (t)	276.0	276.0	291.3	307.1	307.1	306.6	306.6
		Z (t)	196 t	196 t	196 t	216 t	216 t	216 t	216 t

Proceso de montaje - Assembling – Zusammensetzung - Montage- Montaggio - монтаж

1st STEP
OPTION A

TURNTABLE
CABIN SUPPORT

9,600 KG

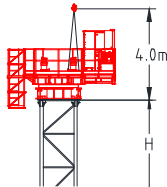

2nd STEP
OPTION A

TOWER TOP SECTION
JIB 1 SECTION

7,600 KG

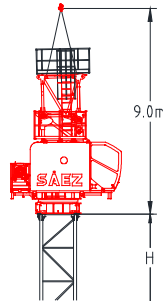

1st & 2nd STEP
OPTION B

TURNTABLE
TOWER TOP SECTION
CABIN SUPPORT
JIB SECTION 1

17,000 KG

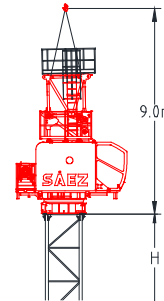

3rd STEP

COUNTERJIB
3,500 KG

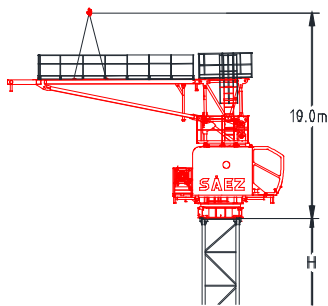

4th STEP

2 x COUNTER JIB BALLAST
2 x 3,500 KG

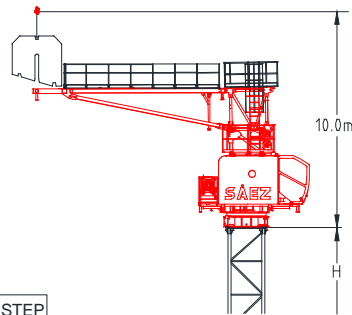

5th STEP

JIB SECTIONS 2, 3, 4, 5, 6, 7, 8 & 9
JIB END
HOISTING UNIT
HOOK

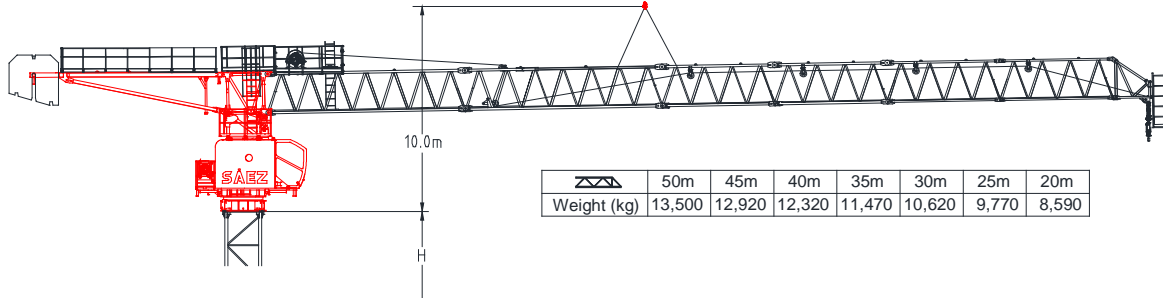

	50m	45m	40m	35m	30m	25m	20m
Weight (kg)	13,500	12,920	12,320	11,470	10,620	9,770	8,590



6th STEP

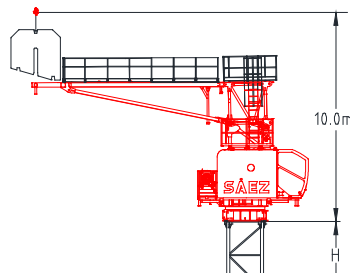

3 x COUNTER JIB BALLAST
3 X 3,500 KG

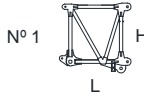
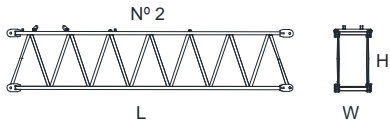
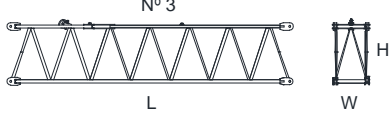
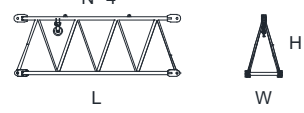
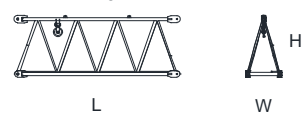
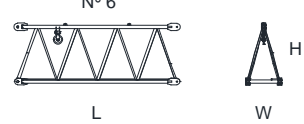
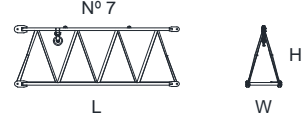
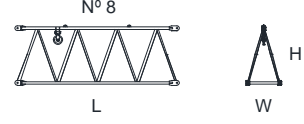
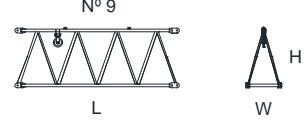
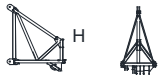

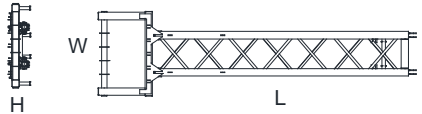
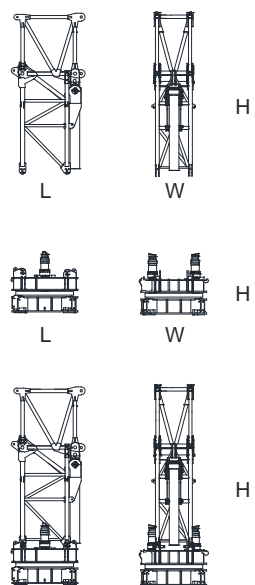

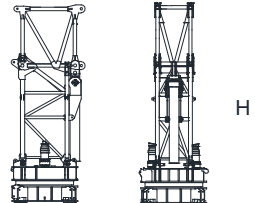
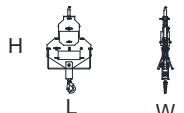
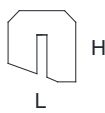
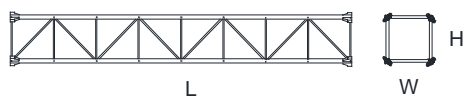
Dimensiones y transporte - dimensions and transport - Abmessungen und Transport - dimensions et des transporte – dimensioni e trasporti - Размеры и транспорта

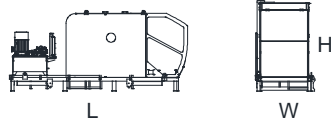
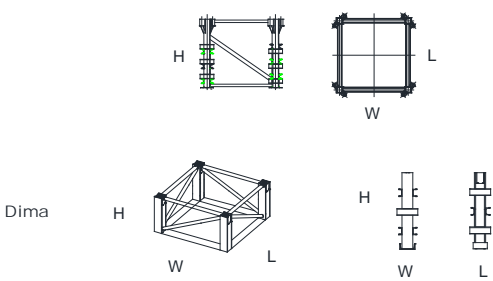
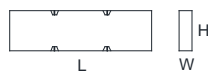
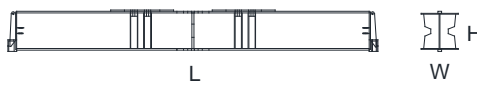
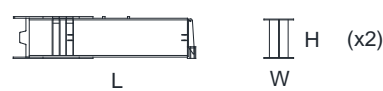
	L(m)	W(m)	H(m)	Peso(Kg)
<p>Pluma tramo primero / Jib heel section / Ausleger-Anlenkstück / Pied de fleche / Settore articolato di braccio</p> <p>Nº 1</p> 	2.26	1.2	2.22	2600
<p>Elemento intermedio de pluma / Intermediate jib section / Ausleger-Zwischenstück / Élément interm. de fleche / Spezzone di braccio</p> <p>Nº 2</p> 	9.02	1.2	2.08	3400
<p>Nº 3</p> 	9.02	1.2	2.06	2400
<p>Nº 4</p> 	5.25	1.2	1.93	1180
<p>Nº 5</p> 	5.21	1.2	1.92	885
<p>Nº 6</p> 	5.21	1.1	1.92	885
<p>Nº 7</p> 	5.18	1.1	1.92	885
<p>Nº 8</p> 	5.16	1.1	1.85	600
<p>Nº 9</p> 	5.16	1.1	1.85	580
<p>Elemento final de pluma / Intermediate jib section / Ausleger-Zwischenstück / Élément interm. de fleche / Spezzone di braccio</p> 	1.81	1.1	2.08	560

	L(m)	W(m)	H(m)	Peso(Kg)
Contrapluma / Counter-jib / Gegenausleger / Contre-fleche / Controbraccio 	8.86	2.28	0.6	3500
Unidad de rotacion / Complete slewing unit / Drehbühne / Orientation / Rotazione 	2.30	1.35	5.10	7100
	2.35	2.35	1.90	6100
	2.40	2.30	6.25	13200
Gancho / Hook / Lasthaken / Crochet / Gancio 	0.8	0.3	1.56	350
Bloque de contrapeso / Counterweight blocks / Gegengewichtsblöcke / Bloc de contrepoids / Blocco di contrappeso 	2.2	0.35	2.2	3500
Elemento de torre / Tower section / Turmstück / Elément de mât / Elemento di torre 	O 11.8 O 5.9 O 3 P 11.8 Q 11.8 X 6 T 6 T 12 U 6 U 12 Z 6 ZR 6	2.27 2.27 2.27 2.27 2.27 2.27 2.27 2.27 2.27 2.27 2.27 2.31 2.31 2.61 2.61	2.27 2.27 2.27 2.27 2.29 2.29 2.29 2.29 2.34 2.34 2.34 2.34 2.34 2.34	5044 2640 1545 5700 5900 4000 4550 9100 6200 12400 5980 8022

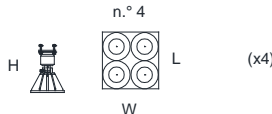
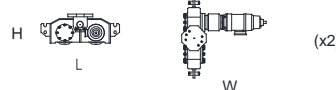
	L(m)	W(m)	H(m)	Peso(Kg)
<p>Cabina y soporte / Cabin and platform / Kabine und wartungs / Cabine et support / Cabina e supporto</p> 	5,2	1,75	2,40	3300
<p>Elemento de empotre / Foundation anchor / Fundamentanker / Pieds de scellement / El anegare</p> 	S70/8 S70R/16 S75R16/20 S75R16/22 S75R16/26 S75R24/30 Dima	2,27 2,27 0,35 0,5 0,5 0,5 2,31	2,27 2,27 0,35 2,0 2,4 2,4 0,8	1122 1274 1200 2840 3160 3600 1650
<p>Bloque apoyo de base / Base support block / Grundballastblöcke / Bloc de appui de base / Blocco di appoggio alla base</p> 	3,75	0,5	1,2	5400
<p>Viga principal base C60HB / Main base beam C60HB / Hauptträger für fundamentkreuz C60HB / Poutre de châssis de base C60HB / Trave principale della base C60HB</p> 	8,65	0,78	0,92	4300
<p>Semiviga secundaria base C60HB / Half base beam C60HB / Halbträger für fundamentkreuz C60HB / Semipoutre de châssis de base C60HB / Semitrave secundaria della base C60HB</p> 	4,27	0,68	0,97	2025
<p>Bloque lastre de base / Base ballast block / Grundballastblöcke / Bloc de lest de base / Blocco di zavorra alla base</p> 	4,4	0,3	1,6	5000

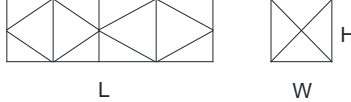
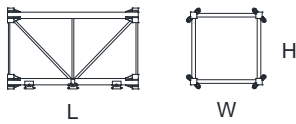
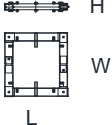
	L(m)	W(m)	H(m)	Peso(Kg)	
<p>Niveladores / Levellers / Spindel pyramide / Niveleurs / Piedi regolabile</p> 	1.20	1.20	0.90	250	
<p>Traslacion / Travelling bogies / Kranfahren / Traslation / Traslazione</p> 	1.15	1.25	0.45	505	
	1.15	0.25	0.45	450	
<p>Jaula de telescopaje tipo O 2.95 / Climbing cage type O 2.95 / Hydraulikbühne O 2.95 / Cage de telescopage type o 2.95/ Gabbia di montaggio O 2.95</p> <p>Completa / Full / Vollständige/Complete / completa</p> 	O-2.95	7,35	2,75	2,75	7000
<p>Estructura / Steel frame / Struktur/ Construction / Struttura</p>	O-2.95				5400
<p>Hidráulico y accesorios / Hydraulic and accessories / Hydraulik-und Zubehör / hydraulique et accessoires / idrauliche ed accessori</p>	O-2.95				1600
<p>Tramo trepador Otr / Tower section Otr/ Turmstück Otr/ Elément de mâture Otr/ Elemento di torre monolitico Otr</p> 	2.95	2.27	2.27	1475	
	11.8	2.27	2.27	4750	
<p>Marco de trepado externo / Tie-frame/ Cadre d'encrage externe / Soplazo con ancoraggio esterno</p> 	2,31	2,31	0,26	950	



40" HC x 7 - HBG 36 m



x 6 - HBG 36 m

Gruas Saez SL reserve the right to alter or amend any information contained in this datasheet without prior notice and no responsibility can be accepted for errors or omissions.